

MM1-4X-XXX-1XX Dora Knx Keypad, RTR Metal

MM2-4X-XXX-1XX Dora Knx Keypad, RTR Plastic

- Prepare scenarios,
- 10 different colours in metal finish, 3 colours option for plastic
- Read room temperature,
- Multiple AC control objects
- RGB Status LED
- 2 inputs, can be set as digital as well as analog via ETS

DORA Series products are KNX bus switch sensor, which can be used as lighting control, dimming, toggle or other programmable objects. It integrates a KNX bus communication module, and has made a special design for the wall flush installation method. The product is equipped with two programmable LEDs for each function button, which can be used as a status display or night light. Single reference (Item code) for entire working keypad. Bus coupler, frame and buttons are contained by.



SWITCH MODELS

MMX-40-24-1XX	
MMX-40-36-1XX	2-4 Control KNX Metal Switch, Temperature read, Thermostat logic + 2 input
MMX-40-48-1XX	3-6 Control KNX Metal Switch, Temperature read, Thermostat logic + 2 input
MMX-40-58-1XX	4-8 Control KNX Metal Switch, Temperature read, Thermostat logic + 2 input
MMX-40-68-1XX	5-8 Control KNX Metal Switch, Temperature read, Thermostat logic + 2 input
MMX-40-78-1XX	6-8 Control KNX Metal Switch, Temperature read, Thermostat logic + 2 input
MMX-40-88-1XX	7-8 Control KNX Metal Switch, Temperature read, Thermostat logic + 2 input

ROCKER MODELS

MM1-40-BTB-1XX	40x80 Metal Button
MM1-40-BTC-1XX	20x80 Metal Button
MM1-40-BTD-1XX	40x40 Metal Button
MM1-40-BTE-1XX	20x40 Metal Button

ROCKER MODELS

MM2-40-BTBP-1XX	40x80 Plastic Button
MM2-40-BTCP-1XX	20x80 Plastic Button
MM2-40-BTDP-1XX	40x40 Plastic Button
MM2-40-BTEP-1XX	20x40 Plastic Button

FRAME MODELS

MM1-40-BTA-1XX	86X86 Metal switch frame
MM1-4T-BTF-1XX	86X127 Metal switch frame, with status LED

FRAME MODELS

MM2-40-BTA-1XX	86X86 Plastic switch frame
MM2-4T-BTF-1XX	86X127 Plastic switch frame, with status LED

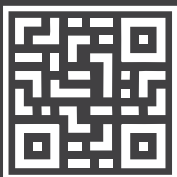

DIMENSION DRAWING

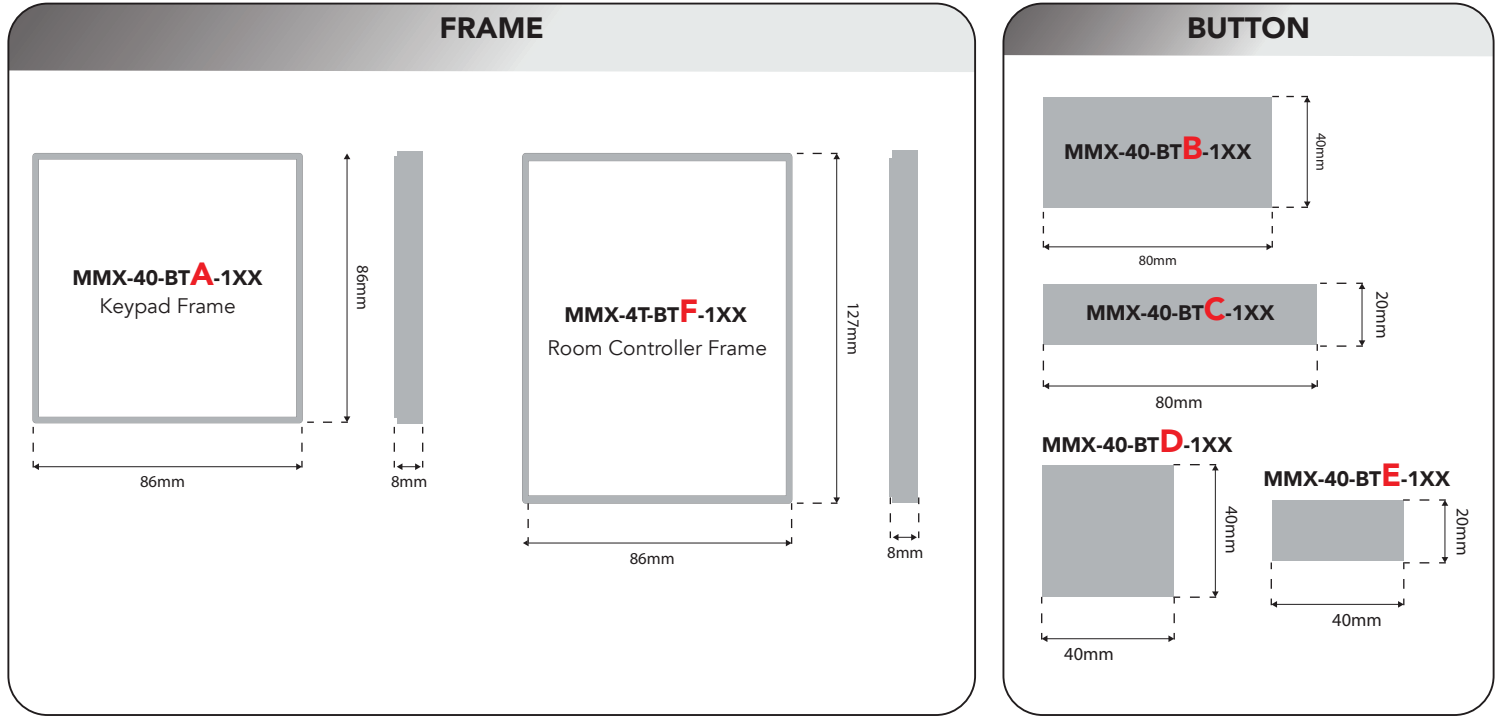

BUTTON CONFIGURATION ON KEYPAD

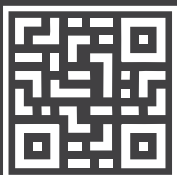
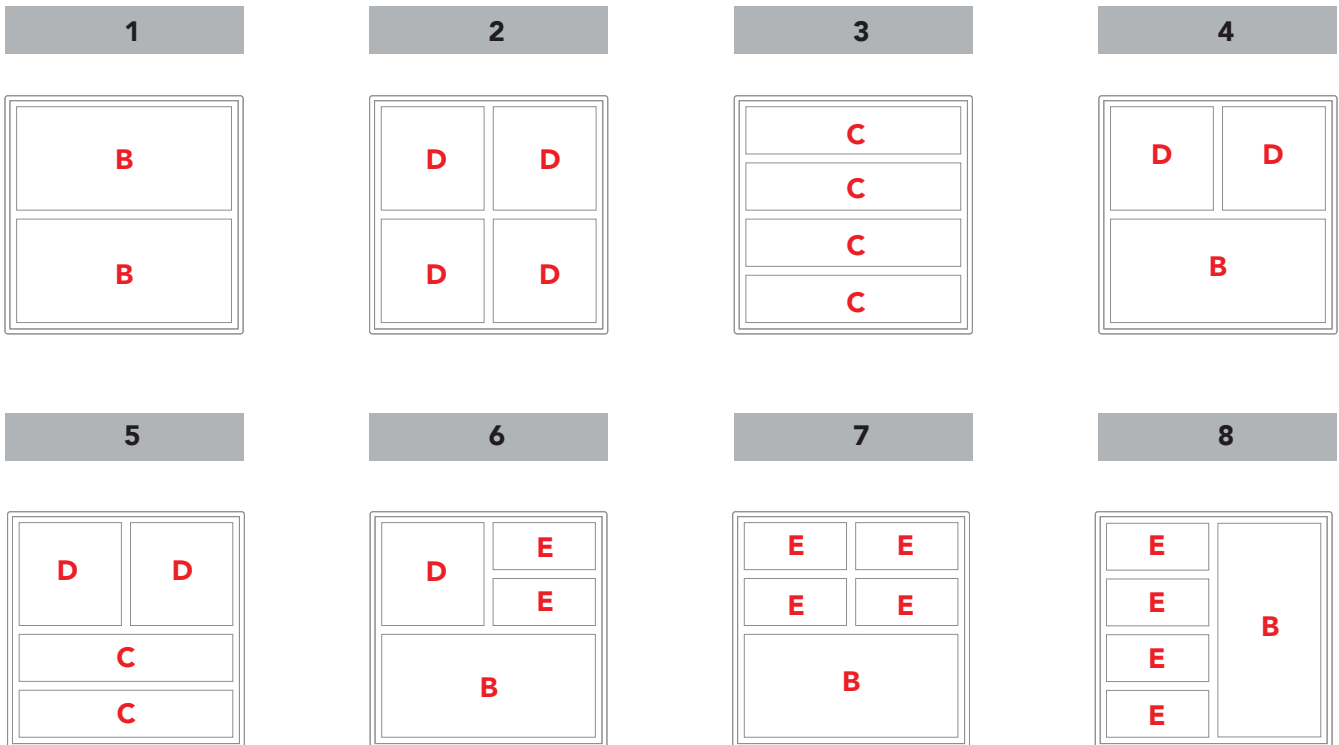

APPLICATIONS

- Switching, toggle, dimming.
- Shutter, blind.
- Value.
- Short press long press step count. external inputs, 2 inputs on the back side (next to KNX connector). These can be programmed via ETS, as digital as well as analog (external sensor (NTC 10K).
- Control of motor drivers (rolling doors, blinds) curtains, etc.
- Call scene.
- Switch to force function (locking)
- Thermostatic parameters
- Running into "programming mode", by pressing programming

SENSOR

- Temperatur and humidity sensors.
- Temperature in Fahrenheit or Celcius.
- Status feedback, configurable RGB LED.

OTHER

- IP20. Protection Grade
- Climate adaptation class 3K5 mechanical class 3m2.(according to EN 50491-2)
- Pollution rating 2(according to IEC 60664-1).
- Dora keypad Weight 140g (including mounting frame)
- Size 86×86×9 mm (border thickness) Length x High x Width
- Dora Room controller weight 200g (including mounting frame)
- Size 86×127×9 mm (border thickness) Length x High x Width
- Size 86×86×9 mm (border thickness)
- Package content: Device with KNX socket, installation support, screw

INSTALLATION

- Having a protective rating IP20, the device is suitable for use in dry rooms.
- Perform the following:
- Fasten the base bracket (g) to the wall bottom box with screw first;
- Secure the key holder (c) on the base (f) while inserting the light guide strip (d) between (b) and (d) sides, and then sequentially insert the face frame (h) and the base holder (f).
- Connect the KNX bus to the terminal first, then insert the terminal behind the product, and download the physical address of the product to the product at this time.
- Buckle the warp switch (a) above the product.

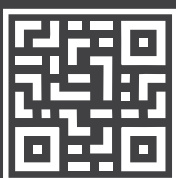
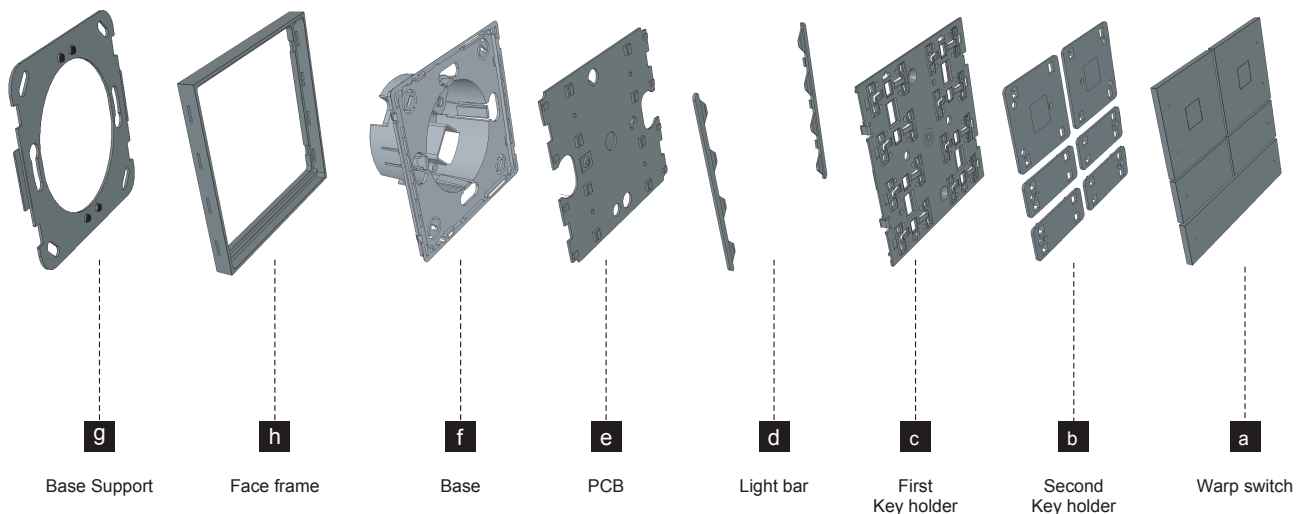
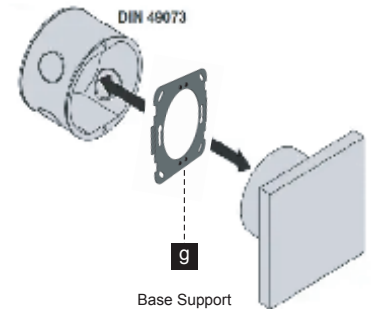

IQ

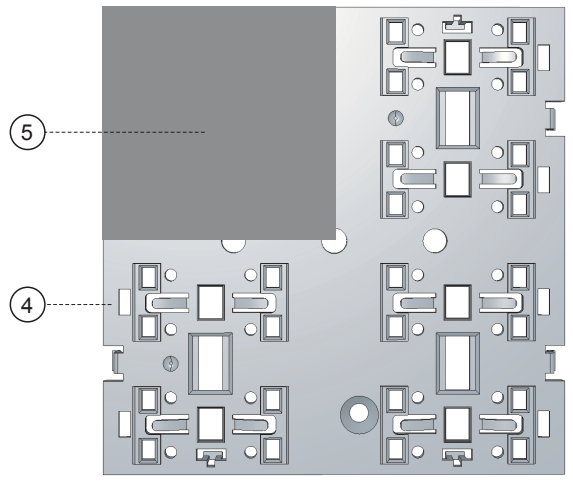
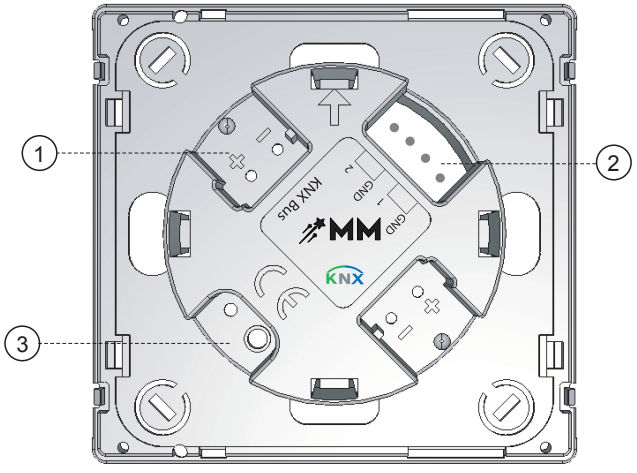

- ① KNX BUS Connection
- ② 2 IO Inputs
- ③ Programming Button

- ④ LED Backlight
- ⑤ Warp Switch: Square Button

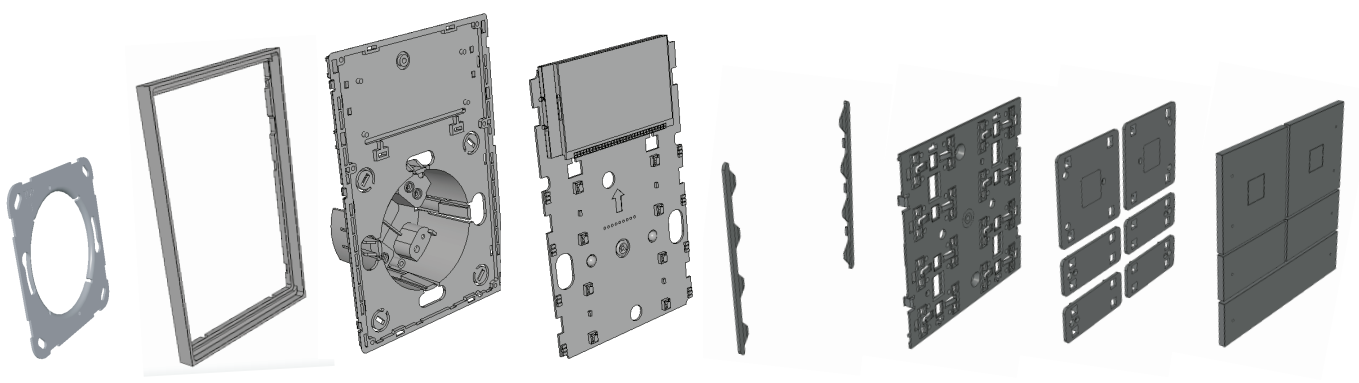

- g** Base Support
- h** Face frame
- f** Base
- e** PCB
- d** Light bar
- c** First Key holder
- b** Second Key holder
- a** Warp switch

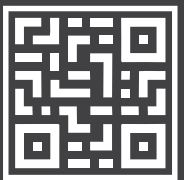

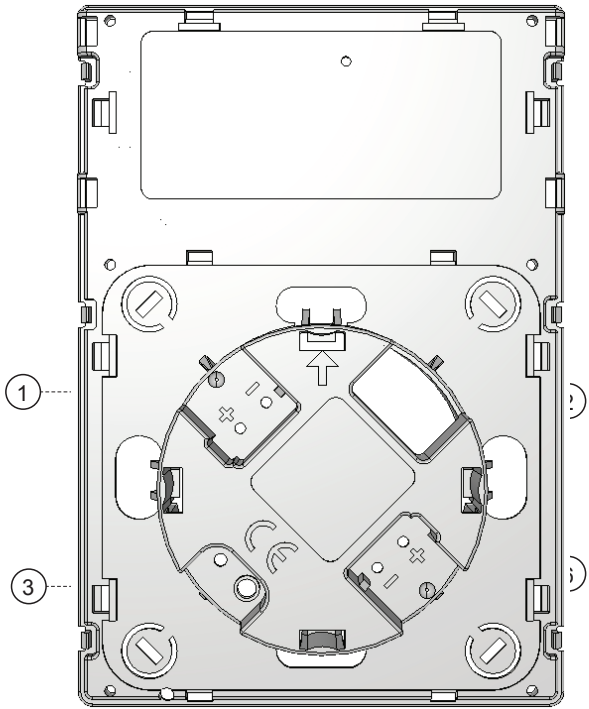

- ① KNX Main link
- ② 2 IO Inputs
- ③ Programming Button

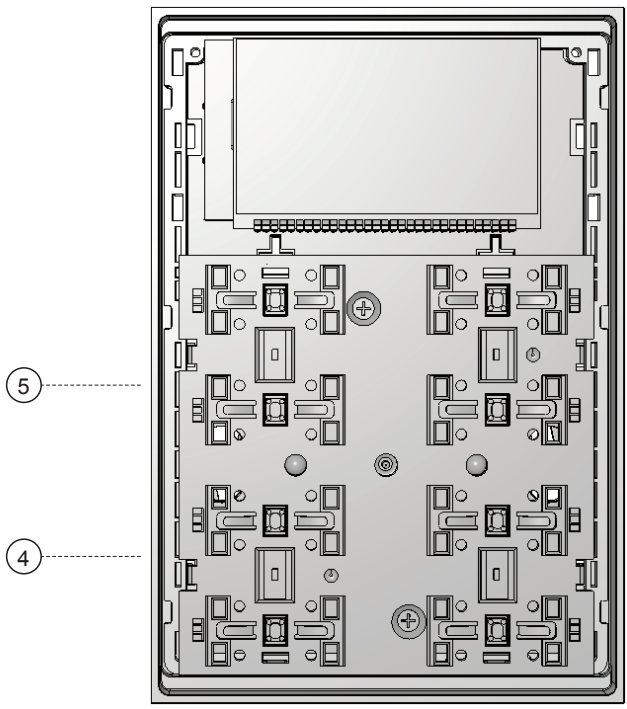

- ④ LED Backlight
- ⑤ Warp Switch: Square Button

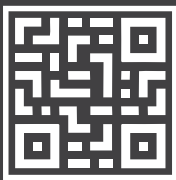

ELEMENTS OF SWITCH, DISPLAY AND CONNECTION

- As a switching switch, the following four points are required. each channel has two LED, a programmable LED and a programmable keypad and a terminal for bus connection.

DISPLAY

- The red LED(5) indicates the current mode, and if the LED is on, the programming mode, when the lights are off, the normal mode of operation.
- Programmable backlights (4) for state feedback or small night lights.

SUGGESTION

- It is best to address the product before installing the rocker. Once the address is specified, there is no need to press the programming button when downloading the subsequent program configuration.

⚠ NOTICE

- Improper installation can cause short circuit or fire. Make sure that the power is turned off before making connections.

DEVICE RESET

- Soft Reset: • First, uninstall the data and product address through the ETS software, and then use the ETS tool to reset the physical and configuration programs before it can be used normally.
- Hard Reset: • Press the programming button to power off, and then press the programming button to power on until the programming LED lights up.

DEBUGGING

- In order to debug the product, follow the steps below;
- Ensure that all electrical connections are carried out in accordance with the above methods;
- Turn on the bus power, press the programming button on the back of the product to switch to programming mode, in which the programming LED is lit;
- Use ETS software to download the physical address and configuration to the product;

⚠ NOTICE

- KNX IT
- The product complies with the EC Directive: Low Voltage (35/2014 EU Directive) Electromagnetic Compatibility (2014 EU/30).
- Test according to EN 50491-4-1.

DISPOSE

- At the end of its service life, the product is classified as e-waste and cannot be disposed of with municipal unsorted solid waste.



- Improper operation or disposal of hazardous wastes may cause serious environmental damage.
- Installation and configuration can only be carried out by qualified professional and technical personnel.
- Illegal opening of the cover of the device will invalidate the warranty.



SWITCH

- The touch button (3) is used to switch between normal working mode and programming mode.
- A tilting switch (5) is used to switch independent loads or set group loads.

⚠ NOTICE

- The programming buttons and LEDs can be observed or operated from the front or back of the product.

CHARACTERISTICS OF KNX BUS

- The wire used for the KNX terminal is preferably a single wire with a wire diameter between 0.6 and 0.8
- The exposed copper part is about 5mm long.
- Color identification: red = + (positive), black = -(negative).

CONFIGURATION AND EQUIPMENT COMMISSIONING

- ETS tool software, version V4 or higher is required to configure and debug equipment. Under the guidance of a qualified planner, configure and debug according to the smart building design plan.

⚠ NOTICE

- Warning! Reset can restore the device to the state when it left the factory. The physical address and parameter value will be deleted during the setting.

SET UP

- In order to set the parameters of the product, the corresponding application or product database needs to be downloaded from the ETS software.

MAINTENANCE

- KNX IT
- The product complies with the EC Directive: Low Voltage (35/2014 EU Directive) Electromagnetic
- Compatibility (2014 EU/30).

